

Georgian Building Code
Earthquake Engineering
(PN 01.01-09)

Chapter I. General

Item 1. Sphere of application

Because of all the territory of Georgia is located in seismic active zone, these Building Codes and Rules are spread on all its territory and it concerns with design of buildings and structures of dwelling houses, social housing and manufacturing facilities both under construction and to be strengthened and restored.

Item 2. Terms and definitions

1. The Building site design seismic intensity – design value of seismic effect expressed in intensities according to the scale of seismic intensity, accelerations or other physical values.

2. Seismic resistance of buildings and structures - the capacity of buildings and structures to maintain the strength and steadiness, considered in design after design earthquake action, that excludes the global or partial failure of the building that can cause the human victims or damages.

3. Aseismic measures - complex of structural and design solutions based on demands of seismic codes providing the seismic resistance level, regulated by codes.

4. Seismic isolation - decreasing of seismic loads, acting on structure using the special structural elements. Such elements are:

a) elements, increasing the structure self-oscillation and ductility (ductile bars, rubber-steel supports etc.);

b) elements, increasing the seismic oscillation energy absorption (dissipation) capacity (absorbers of dry friction, sliding supports, hysteresis, ductile absorbers);

c) standby switch off elements;

d) The limiting supports of the horizontal displacement.

5. Frame buildings - buildings with bearing frames which undertake the whole horizontal and vertical loads.

6. Framed and braced system – the system containing the skeleton frames and vertical diaphragms - walls or stiffening cores, which bear the horizontal and vertical loads. At that,

the horizontal and vertical loads are distributed between frames and vertical diaphragms corresponding to ratio of their rigidity.

7. Braced system - the system containing the skeleton frames and “vertical” diaphragms - walls or stiffening cores, wherein only the diaphragms, walls or stiffening cores bear the vertical loads.

8. Complex structure - the wall consisting of bricks, small concrete blocks or other natural stones, strengthened by reinforced concrete inclusions, which do not create the frame skeleton.

9. The frame with infill - consists of frames, which entirely or partially filled by masonry of natural or artificial stone (brick).

Item 3. General rules

1. Meeting the requirements of these codes and rules are necessary in design of the buildings and structures, which construction is intended on territory of Georgia. These codes and rules should be used in building and construction sector together with other normative documents.

2. These building codes are spread on design of buildings and structures both under construction and to be reconstructed, strengthened or restored.

3. In these building codes and rules there is not examined the issue of design of nuclear power-stations, high dams and other special structures, which are regulated by special codes.

4. The main goal of earthquake engineering codes and rules consists in:

- a) human life security protection;
- b) limitation of building and structure damage degree;

5. These building codes and rules contain demands and analytical models.

6. Building codes and rules are based on necessity of fulfillment of the following demands:

- a) structure is designed by the staff of experienced specialists with corresponding qualification;
- b) The materials used in structure, meet requirements of corresponding standards;
- c) the operation conditions, considered in design, are met;
- d) the systems, corresponding to supervision and quality control of full process are considered - in design institutions, manufactures and building site;

7. The Buildings and structures, which are not examined in these codes and rules or differ from the examined ones, by rigidity, mass distribution and material - need special investigations.

8. The project of adding a storey or extension of existing building is considered as building reconstruction project. The changes, considered in these projects should not decrease the seismic resistance of main building, and not to limit the possibility of works of liquidation of possible damages due to earthquake or other reasons.

9. In design of buildings and structures should be kept the following conditions:

a) should be used the materials, structures and structural schemes, which provide the appearance of seismic strength of minimum values in structural elements,
should be used the materials, structures and structural schemes, which provide the appearance of seismic strength of minimum values in structural elements.

b) should be used the structural schemes with symmetrical and even distribution of rigidity and masses in the plan as well as vertical plane.

c) in buildings and structures, made of prefabricated constructions the butts between elements should be arranged out of the area of maximum stress appearance;

d) in case of structure large displacements, its integrity and uniformity should be ensured, using the consolidated prefabricated elements;

e) the structure as the unified system should be verified on the steadiness, sliding and overturn.

f) should be verified: the capacity of the foundation elements and "soil-foundation" block, to resist the effect, due to the building reaction, without significant permanent deformation.

g) in case of the structure large horizontal displacement, the building inclination from vertical axis becomes significant and the gravity force (dead weight) creates the moment relative to base (so called, second range effect), that necessarily should be considered in calculation;

h) for case of design seismic effect, should be verified, how much dangerous are the nonstructural element behavior to people, and what harmful effect occurs it on the structure main element response.

10. For ensuring of the structure ductile behavior must be excluded the premature formation of the brittle destruction or the unstable mechanisms.

11. The structure seismic resistance depends on the behavior of critical zones or the elements. In design, the providing of connection between the structural elements and dissipation zones should be the subject of particular thought.

12. The structural calculation model should provide the possibility of consideration the soil deformability and work of nonstructural elements.

13. It is possible to change structure under construction or in the operation period, without corresponding verification and establishment, even if this change causes the structure resistance increasing.

14. The measures of the existing building reconstruction or old damaged building restoration strengthening should be realized based on the specially elaborated project, in which the retrofitting (rising of seismic resistance up to design value or increase to the certain level) is considered. The increasing of the existing building seismic resistance can be achieved by way of the following measures:

- a) bringing in the changes into the existing building and structure spatial-design solution, that means to: divide the building complex structural scheme into the simple zones by way of anti-seismic joint arranging; take of the upper floors or change the building structural scheme by arranging of the additional bearing elements or systems, which will be considered to take the certain part of seismic load;
- b) strengthening of frame structures, bearing walls and their joints, that provides the capacity to bear the increased seismic effect;
- c) increasing the building and structure floor rigidity;
- d) increasing the connections between prefabricated reinforced concrete elements;
- e) arranging the reinforced concrete anti-seismic belts;
- f) decreasing the nonbearing element mass using the lightweight materials;
- i) arrangement of the seismic isolation structural elements or special seismic isolation pads;

15. In building and structure design, the seismic effect should be considered according to the map of seismic hazard on the territory of Georgia. In annex 1 there is given the map, on which the hazard is expressed in peak accelerations (maximum horizontal acceleration) and in annex 2 there is given the list of settlements, where for each concrete district the design intensity and design peak acceleration is indicated. Intensities and peak accelerations indicated in annexes belong to soils with average seismic properties (category II according to the Table 1).

16. The building site seismic intensity should be defined more accurate according to the microzoning map. For districts, where the microzoning was not conducted - there is

acceptable the determination of the building site seismic activity using the map of seismic hazard on the territory of Georgia (Annex 1) and the Table 1. If the design seismic intensity increased or decreased corresponding to the soil conditions, the design maximum horizontal acceleration indicated in Annex 1, increases or decreases double.

17. The building site, that is located on the slope tilted greater than 15° , or is characterized by physical-geological processes as are: strong decomposition of rocks, landslides, snow-slides, karsts, sliding rocks, from the seismic point of view, does not represent the advantageous site. The localization of these districts and assessment of the seismic hazard is conducted at fulfillment of microzoning works. In case of necessity of the building or structure construction on such site, the conduction of the additional measures for foundation and structure strengthening is necessary.

18. For soils, characterized by subsidence, those by their seismic properties belong to the III category, the avoiding of their subsidence property is necessary. In calculation of structures subjected to the seismic action, the additional forces, arose due to the uneven subsidence of the soils, should be considered.

19. In assessment of the building site seismic intensity, that can be realized using the microzoning, or the Table1, the foundation type (among them piles) and depth are not considered.

Table 1

Soil categories according to the seismic properties	Soils	Seismic Intensity		
		7	8	9
		Design seismic intensity of building site		
I	Rocky soils unweathered and weakly weathered, without cracks and weakly chapped; gapped . Soils with large debris, dense, with loamy sandy filler up to 30%, of low humidity. The average velocity of transversal wave propagation $V_s > 800$ m/sec	6	7	8
II	1. Rocky soils weathered, very weathered and very chapped; 2. Soils with large debris, which do not belong to the I category; 3. Sands with gravel, large and average grain sizes, dense and the average density, the low humidity and humid; 3.1. Sands of fine grain and dusty, dense of the average density, and the low humidity; 4. Loamy soils with consistence index $I_L \leq 0,5$, coefficient of porosity $e < 0,9$ for loamy soils, and $e < 0,7$, for sandy soils.	7	8	9

	The average velocity of transversal wave propagation $V_S=300\div 800$ m/sec.			
III	<p>1. Friable sands, in spite of humidity and grain sizes;</p> <p>1.1. Sands with gravel, with large and average grains, dense and the average density, water-saturated;</p> <p>1.2. Sands of fine grain and dusty, the dense and the average density, humid and water-saturated;</p> <p>2. Loamy soils with consistence index $I_L > 0.5$;</p> <p>2.1. Loamy soils with consistence index $I_L \leq 0.5$, the coefficient of porosity $e \geq 0,9$ for clays and loamy soils, and $e \geq 0,7$, for sandy soils.</p> <p>The average velocity of transversal wave propagation $V_S=100\div 300$ m/sec</p>	8	9	>9
IV	<p>Very weak soils: the bottom sediment, contemporary organic, made ground, watersaturated soils with trend to liquefaction etc.</p> <p>The average velocity of the transversal wave propagation $V_S < 100$ m/second.</p>	Seismic intensity is made more precise in result of special investigation		

Notes:

- 1) The thickness of rocky soil layer should be no less then 30 m;
- 2) In case of the unhomogenic soils of the building site, by their seismic properties they belong to category of most nonadvantageous soils, if in limits of 10 meter capacity layer (from design level) the nonadvantageous layer has capacity greater than 5 m.

Chapter II. Design loads

Item 4. Design loads

1. Calculation of the building and structure constructions and foundations should be conducted for the basic and particular combination of the loads considering the seismic effect. In calculation of buildings and structures subjected to the particular combination of loads, the design loads should be multiplied by combination coefficient, given in Table 2.

Table 2

Types of loads	Value of the combination coefficient
Permanent	0,9
live load, temporarily long-term (on floor)	0,8
live load, temporarily instantaneous (on floor and covering)	0,5

The particular combination of the loads considering the seismic effect does not contain the horizontal forces imposed to the masses connected to the structures by ductile pendants, temperaturational –climatic effects, wind loads, dynamical loads due to the facilities and

transport movement, stresses due to the crane movement and braking. In the determination of the vertical forces there should be considered the weights of crane bridges, crab and luggage, that is accepted equal to 0,3 of the crane lifting. The horizontal design seismic load due to the weight of the crane bridge should be applied to the undercrane beam in the axis perpendicular direction. . In this case load decreasing is not considered.

2. The calculation of the buildings and structures considering the seismic action should

be fulfilled:

- a) subjected to the loads defined by the clause 6 of this item (by spectral method);
- b) using the instrumental records of the basis seismic accelerations and synthesized accelerograms.

3. According to subclause "a" , of clause 2, the calculation is necessary for all buildings and structures, and according to subclause "b" It is calculated the high-rise (with number of storeys greater than 16) buildings and structures, and those equipped by seismic isolation and other seismic response regulation systems. In these calculations the possibility of nonlinear deformation development process should be considered. The buildings and structures should be designed subjected to the most disadvantageous loads, accepted in sub-clauses "a" and "b".

4. The direction of seismic action in the space is random. The buildings and structures having the simple geometrical form are calculated subjected to the horizontal seismic loads, acting in longitudinal and transversal directions separately. The buildings and structures having the complex geometrical form, the calculation should be fulfilled, suffering seismic effect in the most disadvantageous direction for the given structure or its elements.

5. The vertical seismic load should be considered in calculation of:

- a) the horizontal and inclined cantilever structures, frames, bridge spans;
- b) The arches, trusses and spatial coverings of the building and structure, which spans are greater than or equal to 24 m;
- c) The structures, which need to be calculated on turnover or sliding;
- d) The buildings with large-block or the brick bearing walls;
- e) The seismic isolation supporting elements.

6. The seismic load S_{ik} , acting in point "k" in the given direction, corresponding to the building or structure self-oscillation tone "i" is determined by expression:

$$S_{ik}=K_1K_2K_3S_{oik} \quad (1)$$

where, K_1 is the coefficient considering the admissible damages in the building, the structure capacity to develop nonlinear deformations, and other reserves of seismic resistance (Table 5).

K_2 is the coefficient considering the structural solution of the buildings and structures (Table 4).

K_3 – the coefficient considering the building or the structure significance (Table 5).

S_{oik} - the seismic load corresponding to the building or structure, as the elastic-deformable system, self-oscillation "i" tone, that is determined by the expression:

$$S_{oik} = Q_k A \beta_i K_\psi K_0 \eta_{ik} \tag{2}$$

where, Q_k is the weight of the building or structure, applied in point "K", that is determined considering the design loads defined in the clause 1 of this item (Fig. 1);

A – The seismic nondimensional coefficient that shows ratio of the soil design acceleration to free fall acceleration for given settlement (Annex 1);

β_i - coefficient of dynamics, corresponding to the building or structure self-oscillation "i" tone, that is determined by the expressions (3)-(5), or diagram (Fig.2);

K_ψ - coefficient that is determined by the Table 6;

K_0 - coefficient, considering the soil nonlinear deformation (Table 4.1), it is used when the coefficient of the soil category is determined based on Table 1, without the seismic microzoning conduction;

η_{ik} - coefficient that depends on the deformation type corresponding to the building or structure self-oscillation "i" tone and on location of the load, defined by the clause 8 of this item.

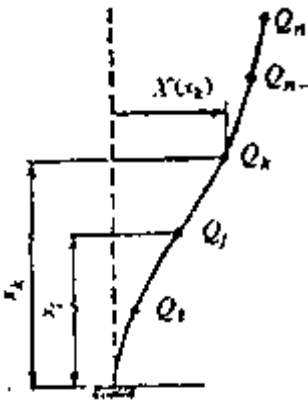

Fig. 1

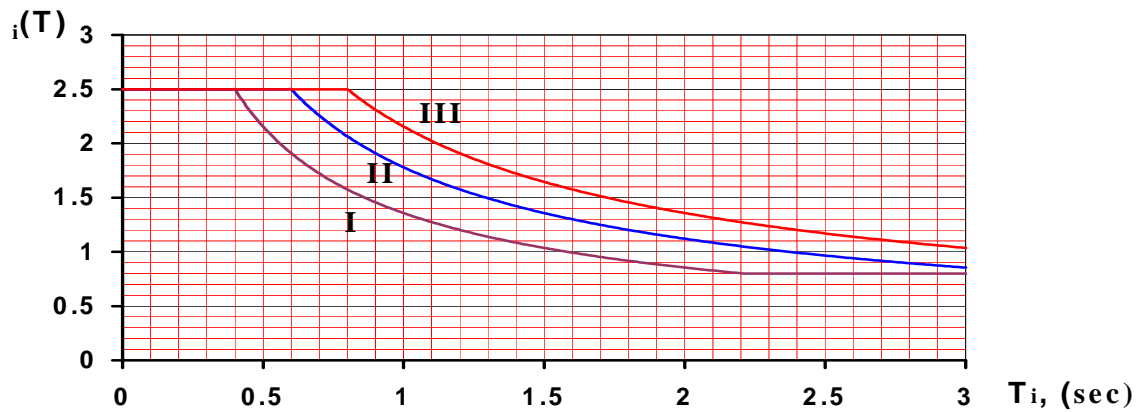

Fig.2

Table 3

The structural solution of the bearing element and system	Value of the coefficient K_1
1. Structures, for which damages and nonlinear deformations are inadmissible	1,0
2. The bearing steel skeleton	0,25
3. The reinforced concrete skeleton	0,35
4. The Large-panel bearing walls and walls of the monolithic reinforced concrete	0,30
5. Bearing wall of the stone and brick masonry.	0,40
6. Bearing supports of the buildings with seismic isolation systems	0,60
7. Building elements, which are calculated subjected to the "local" seismic loads (skeleton infill and partitions in calculation out of the plane, parapets, railings)	0,50
Note: according to the clause 6, in calculation of the upper floors, the value of coefficient K_1 is accepted corresponding to the structural solution of these floors.	

Table 4

Structural solution of the bearing element and system	Value of coefficient K_2
1. Buildings with frame, large block and complex structure walls, with number of storeys greater than 5	$K_2=1+0,1(n-5)$
2. Large-panel buildings and the monolithic concrete walls, with number of storeys no greater than 5	0,9
3. The buildings of the same structure, with number of storeys greater than 5	$K_2=0,9+0,075(n-5)$
4. The buildings, which one or a few lower floors are frame, and upper ones with bearing walls (diaphragms or frame with infill), if lower floors have not infill, or they have a small influence on	1,5

the frame rigidity.	
5. Brick and stone buildings with the hand made masonry bearing walls, without additions for mortar coherence increasing	1,3
6. Frame one-storey buildings, which height up to the lower level of the beams or trusses no greater than 8 meter, and the span is up to 18 m.	0,8
7. Agricultural buildings with the column-piles on soils of the category III (according to table 1)	0,5
8. Buildings and structures which are not indicated in the clauses 1-7	1,0

Notes: 1) n - the number of storeys;

2) the value of K_2 should not exceed 1,5;

7. The coefficient of the dynamics is determined by the (3-5) expressions, or diagrams, given on Fig.2, corresponding to the building or structure self-oscillation "i" tone and soil seismic property category:

Soils of the category I	Soils of the category II	Soils of the category III
$0 \leq T_i \leq 0,4$ $\beta = 2,5$	$0 \leq T_i \leq 0,6$ $\beta_i = 2,5$	$0 \leq T_i \leq 0,8$ $\beta_i = 2,5$ (3)
$0,4 \leq T_i \leq 2,2$ $\beta_i = 2,5x(0,4/T)^{2/3}$	$0,6 \leq T_i \leq 3,0$ $\beta_i = 2,5x(0,6/T_i)^{2/3}$	$0,8 \leq T_i \leq 3,0$ $\beta_i = 2,5x(0,8/T_i)^{2/3}$ (4)
$T_i > 2,2$ $\beta_i = 0,8$	$T_i > 3,0$ $\beta_i = 7,5x0,6^{2/3} T_i^{5/3}$	$T_i > 3,0$ $\beta_i = 7,5x0,8^{2/3} / T_i^{5/3}$ (5)

Note: For all cases β can not be less than 0,8.

8. For the buildings and structures which are calculated by the cantilever calculation scheme, the coefficient η_{ik} is determined by the expression

$$\eta_{ik} = \frac{X_i(x_k) \sum_{j=1}^n Q_j X_i(x_j)}{\sum_{j=1}^n Q_j X_i^2(x_j)} \quad (6)$$

where, $X_i(x_k)$ and $X_i(x_j)$ are displacements, corresponding to the oscillation "i" tone, of point "k" and points, in which, according to calculation scheme, the weights are concentrated (fig.1);

Q_j is the weight of the building or structure, concentrated in point "j" that is calculated according to the clause 1 of this item.

9. For the buildings and structures with self-oscillation period $T_1 < 0,4 \text{ sec.}$, the number of the storeys no greater than 5, and distribution of the masses and rigidities by the height changes insignificantly, the coefficient η_k can be calculated by the simplified expression

$$\eta_k = \frac{x_k \sum_{j=1}^n Q_j x_j}{\sum_{j=1}^n Q_j x_j^2} \quad (7)$$

where, x_k and x_j are distances from k and j points to the foundation upper edge.

10. If the value of the building and structure self-oscillation first tone period exceeds 0,4 sec., the stresses, acting in the structures and their elements, should be determined considering no less than three forms of the self-oscillation, and in the case of flat calculation model, if T_1 is less or equal to 0,4 sec - considering only the first form.

Table 4.1

Values of the coefficient K_0 , that considers the soil nonlinear deformation at intensive seismic oscillations

The soil category	Seismic intensity		
	----- Maximum horizontal acceleration		
	7 ----- 0,05 - 0,12	8 ----- 0,121 - 0,24	9 ----- 0,241 - 0,52
I	1,0	1,2	1,3
II	1,0	1,0	1,0
II	1,0	0,8	0,75
IV	According to the data of special investigations		

Table 5

Characteristic of the buildings and structures	Value of the coefficient K_3
1. Dwelling , social and manufacturing buildings and structures, except the listed in the clauses 2-3	1,0
2. Large railway stations, theatres, movie theatres, airport buildings, covered stadiums, shopping centers, high education institutions, schools, kindergartens, hospitals, power and water supply objects, buildings of fire safety, telephone and television systems, police, banks, republic, city and local administrative bodies.	1,4
3. The buildings and structures, which destruction does not cause human victims, getting out of order of expensive facilities and stopping of continuous process of manufacturing (storages, crane bridges, access platforms, small shops, agricultural buildings etc.)	0,5

11. Transversal and longitudinal forces, bending and overturn moments, normal and tangential stresses induced in structures due to the static action of the seismic loads, defined in clause 6 of this item, are calculated by expression

$$N_p = \sqrt{\sum_{i=1}^n N_i^2} \quad (8)$$

where, N_i is the value of the force or stress in section under examination, caused by the seismic load, corresponding to "i" form of oscillation;

n - the number of the forms, considered in the calculation

12. The vertical seismic loads applied to the structures, implied in clause 5 of this item (except the brick and large block ones) are determined by the expressions (1) and (2). In this case coefficients K_ψ and K_2 are accepted equal to 1. The cantilever structures, which weight is insignificant comparatively to the building (balconies, railings, suspended cantilever walls etc., and their embeddings) for vertical loadings are calculated considering $\beta\eta = 5$.

13. The structures, located above the basic part of the buildings and structures, as are parapets, frontons etc., and embeddings of different facilities, subjected to the seismic load are calculated by the expressions (1) and (2), considering $\beta\eta = 5$.

14. Nonbearing walls, panels, partitions, joints between the different structures, as well as embeddings of the processing plants, subjected to the horizontal seismic load, should be calculated by the expressions (1) and (2), considering the $\beta\eta$ value, corresponding to the building level under examination, but not less than $\beta\eta=2$. The friction forces should be taken into consideration only in calculation of the horizontal joints of large panel buildings.

15. In calculation of the structure strength and steadiness, except the coefficients of work conditions, defined in other chapters of the Building Codes and Rules, there should be considered the additional coefficient of work conditions m_{short} , that is defined according to the Table 7.

Table 6

The structural solution of the buildings and structures	Value of the coefficient K_ψ
1. High-rise structures with the plan of small sizes (towers, masts, chimneys, detached lift shafts etc.)	1,5
2. Frame buildings, which wall infill has insignificant influence on its deformability, and ratio of column height to cross-section size (in	1,5

direction of the seismic force action) is equal or exceeds $h/b=25$.	
3. The same, that in position 2, with only difference, that above mentioned ratio exceeds $h/b=15$.	1,0
5. The buildings and structures which in positions 1-3 are not indicated.	1,0

(Notes: 1) For intermediate meanings of the ratio h/b the coefficient K_{ψ} is selected by way of interpolation; 2) In case of floors of different heights the coefficient K_{ψ} is selected by the average value of ratio h/b).

Table 7

Structures of	Value of coefficient m_{short}
1. Steel and timber	1,4
2. Reinforced concrete with the bar and wire reinforcement (which strengths of inclined cross-sections, are not verified):	
a) heavy concrete with reinforcement of the classes A-I, A-II, A-III, Bp-I	
b) the same with reinforcement of other classes	1,2
c) the concrete with porous aggregates	1,1
d) the cell concrete with reinforcement of any class	1,1
3. Reinforced concrete, which strength of inclined cross-sections, are verified:	1,0
a) the columns of high-rise buildings	
b) other elements	0,9
4. Stone, reinforced stone and concrete:	1,0
a) subjected to excentric compression	
b) subjected to the shear and tension	1,2
5. Welded joints	1,0
6. Joints by the screws and clinchers (in verification of steadiness)	1,0
7. the steel elements with ductility greater than 100	1,1
8. The same with ductility up to 20	1,0
9. The same with ductility from 20 to 100	1,2
	From 1,2 to 1 (Interpolation)

16. The buildings and structures, which one size exceeds 30 m, must be calculated subjected to the torsion moment, acting relative to the vertical axis, through-passing the building or structure rigidity center, beside the seismic loads, defined in the clause 6 of this item. The design eccentricity, existing between the building or structure rigidity and masses for level under examination has been accepted not less than $0,02B$, where 'B' is the size of the building or structure in plan perpendicularly to the action of the seismic force S_{ir} .

17. In calculation of support walls the soil seismic pressure should be considered.

18. For reinforced concrete and stone bearing elements the limitation of the limit permissible value of γ parameter is needed

$$\gamma = \frac{Q}{B} \quad (9)$$

where, Q is the design value of total static loads due to the dead load and other vertical static loads, acting in the most loaded cross-section of the building bearing structural elements; Here 'B' is the design total value of the vertical load bearing capacity of the same cross-section of the building structural element .

Table 7.1

The limit permissible value of γ parameter for reinforced concrete and the stone bearing structures

Design intensity of seismic action on building	Design value of γ parameter
7	0,80
8	0,65
9	0,50
10	0,35

Item 5. Direct Dynamic Analysis of Design Seismic Effect Employing the Time Function

1. In direct dynamic effect analysis, the maximum design amplitude of basis horizontal acceleration should be accepted no less than that indicated in Annex 1.
2. In case of lack of instrumental records, in the direct dynamic analysis the basis design vertical acceleration is accepted equal to 0,7 of the design horizontal acceleration.
3. When established data about basis acceleration spectral composition and nonstationarity in time of the basis acceleration (amplitude envelope) exist, there is the permissible use of the array of the synthetic accelerograms, those are obtained based on these data by way of the computer modeling.
4. When the confirmed map of the seismic microzoning exists and it contains the numerical parameters of the predicted seismic effect, the design value of the basis accelerations, characteristics of the spectral composition and nonstationarity in time, design accelerograms – should be taken corresponding to the data of this map of seismic microzoning.
5. The instrumental accelerograms of strong earthquakes, recorded in the seismic and soil conditions, similar to ones of the structure or building site under design, should be used in direct dynamic analysis in addition to the array of synthetic accelerograms. At

that, the maximum design accelerations of the instrumental accelerograms should be standardized according to the acceleration values, given in the clause 1 of this item.

6. The seismic load values, structure displacements and deformations should be determined considering the peculiarities of the structure nonlinear deformation.
7. The building and structure direct analysis using the design accelerograms, as the casual process realization, including the statistic treatment rule and interpretation of the calculation results – should be carried out based on the corresponding research.

Chapter III. Dwelling, Social Housing and Industrial Buildings and Structures

Item 6. General

1. The structure should have simple and regular form, which realization is possible by the division of the structure into dynamically simple sections by anti-seismic joints.
2. The sizes of the sections (distance between aseismic joints), as well as the building height should not greater than the data given in the Table 8. In hospitals, the operating theatre and resuscitation department should be located on two lower floors.
3. The aseismic joints need to be limited by arranging of coupled walls or frames, as well as the frame and wall. The width of aseismic joint (slit) must be determined by the calculation, however, the following conditions need to be met: for building and structure up to 4 meter high, the aseismic joint width should be no less than 33 mm, and for higher buildings, the joint width should be increased by 20 mm after each 5 meter along the building height.
4. The aseismic joint has to divide the building along all height. Foundation without the seismic joint is admissible except the case, when the aseismic joint coincides with the building or structure subsidence joint. The structural solution of aseismic joint should not put obstacles in the way of horizontal displacements of the building or structure isolated sections at earthquake.

Table 8

N	Building bearing structures (Structural schemes)	Number of floors		
		Building site seismic intensity		
		7	8	9
1.	Steel frame with bracing or diaphragms	24	20	16
2.	Monolithic reinforced concrete walls	20	16	14
3.	Reinforced concrete frame:			

	a) with bracing, reinforced concrete diaphragms or stiffening cores	16	12	9
	b) frame with brick or small block infill	9	7	5
	c) girderless frame with reinforced concrete diaphragms or stiffening cores	9	7	5
	d) frame, which wall infill of does not influence the frame rigidity	6	5	4
	e) the frame with bearing brick walls	4	3	2
4.	Reinforced concrete large block walls	14	12	9
5.	Three-dimensional block buildings	12	9	7
6	Large block buildings	7	6	5
7	Walls of complex structure (brick, small block)	6	5	4
8	Brick or small block masonry walls strengthened by reinforcement	5	4	3
9.	Brick or small block masonry walls without strengthening	4	3	2
10	Timber buildings	3	2	1
11	Buildings made of local materials	2	1	1

Notes:

1. For dwelling houses the height of floor should not exceed 4,0 m.
2. The number of floors of buildings for children and school institutions should not exceed 3 above ground.
3. On building sites the length of building between seismic joints for timber buildings should not exceed 40 m in case of intensity 7 and 8, and in case of intensity 9 – 30 m; for the rest of the buildings 80 and 60 m respectively.
4. The design and construction of buildings, with number of storeys greater than ones, indicated in clauses 1, 2 and 3 of table 8, permissible, if the demands given in Annex 3 are considered.
5. From point of view of regularity, structures are divided into regular and irregular types. Mentioned division defines the following aspects of seismic design:
 - a) structure model, which simplification possible in plane or in space;
 - b) methods of analysis, in which many forms of oscillation can be used, or calculation is simplified, using only one form;
 - c) in calculation of irregular building using the spectral method, the value of coefficient K_1 should be respectively established.
6. The regularity criteria in the plan are following :
 - a) the building structure in two orthogonal directions of the plan approximately symmetrical from point of view of rigidity and mass distribution;
 - b) the configuration compact in the plan, i.e. it does not contain complex contours as are H, I, X and other forms.;

- c) the maximum sizes of indents and projections in one direction do not exceed the 25 % of building outer size in the corresponding direction;
- d) the rigidity in plane of the floor big enough comparatively to the horizontal rigidity of the structure vertical element, so the floor deformation influences insignificantly the force redistribution between the structure vertical elements;
- e) if the seismic load, determined by the simplified scheme (considering only oscillation the first form) is applied to the building eccentrically, considering the casual eccentricity, that on each floor equals to 5 % of floor size in the direction normal to force action , then the maximum additional displacement in direction of force action in limits of any floor, should not exceed 20% of floor average displacement (influence of casual eccentricity).

7. The regularity criteria in height are following:

- a) all systems, subjected to the horizontal loads, as are stiffening cores, bearing walls and frames do not suffer gap from the foundation to the end of the building or they have certain indents along building height;
- b) the horizontal rigidity and mass of each floor from the foundation to the end of the building is permanent or changed shallowly, without rapid changes.
- c) in case of indent existing, following additional demands are accepted (Fig. 3): in case of step-by-step indent, when the axial symmetry is kept, the indent in any floor should not exceed 20% of preceding floor size in the plan in the direction of indent (Fig.3, a, b); in case, when the indent exists in the bottom of building, on level of 15 % of basic structural system – the indent should not exceed 50 % of size in plan. In this case, the structure of the foundation zone in limits of the upper floor vertical projection parameters should be designed to resist to no less then 75% of horizontal shear, without foundation size increasing (Fig 3, c); In case of asymmetric indents existing in façade, the sum of indents must not exceed 30% of size in plan of first floor, and the indent of each floor – 10% of size of preceding floor (fig.3, d).

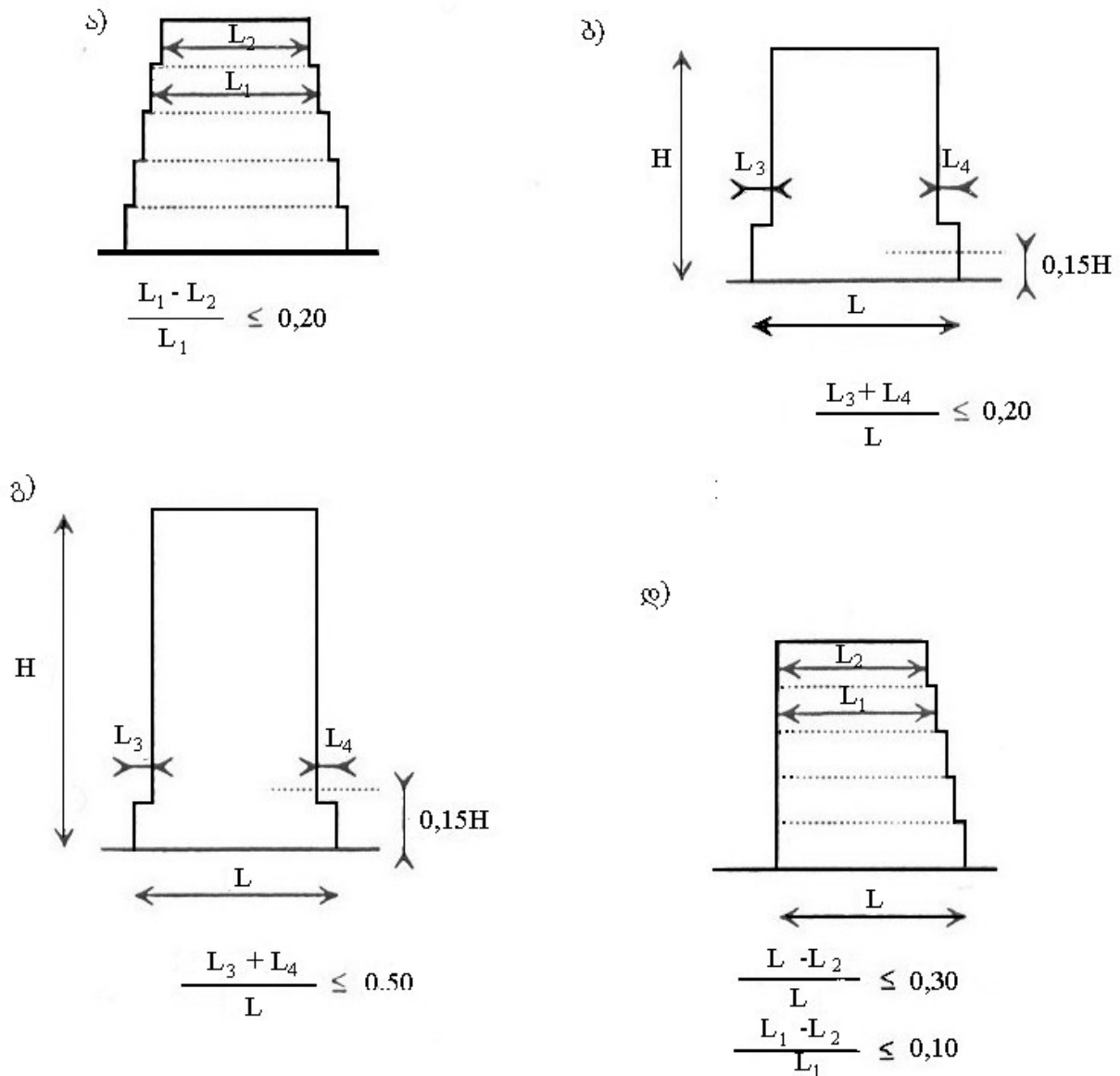

Fig. 3

8. The building nonstructural elements (parapets, frontons, additional mechanical facilities, frame infill walls, partitions, railings etc.), which in case of failure can cause human victim or affect the building basic structure or facility operation, must be verified subjected to the seismic effect, together with their supports. The rigidity of such elements should be considered in the calculation scheme and in the selection of response spectra.

Item 7. Foundations and Basement Floors

1. The building foundation should have rigidity enough, to transmit to soil the effect, accepted from structures above ground. The calculation and construction of the

building and foundation connected to it, should ensure the seismic movement of the building and structure as the united system.

2. In buildings and structures if it does not contain dynamically simple elements, foundations of one type should be used.
3. For buildings and structures to which foundations the forces are transmitted pointwise, there should be considered the foundation slab or foundation girders in both main directions.
4. For buildings, with number of storeys greater than 10, the foundation on earth should be realized with piles or as the foundation slab or in combination of the reinforced concrete slab and piles; the slab bottom level is defined by the level of basement bottom that is necessary to do and its depth from vertical design level should be no less than 2,5 m.
5. In design of foundation with piles, the lower ends of piles should be submerged in the soil of category I and in some cases –II, cutting the friable upper layer. In limits of building, the upper ends of piles should be embedded into grillage on one level. The grillage desirable to be buried entirely into the soil.
6. For foundations with piles can be used all kind piles except the wedge-like ones and piles without transversal reinforcement. The use of driven in piles permissible only in stable soils which do not require the strengthening of borehole walls, at that the pile diameter should be no less than 400 mm, and pile length ratio to its diameter, no greater than 25. To cut the watersaturated soils by driven in piles permissible, if defense pipes are used.
7. Arranging of pile foundations without grillage (the upper part of pile foundation in appearance of concrete or reinforced concrete slab or beam, that combines the piles into one stable system and distributes the load equally to piles) unacceptable.
8. If in available depth of the basis the soils of category III exist, the pile foundation can be realized with so called middle pad, that decreases the transmission of the horizontal forces to building.
9. The foundations of buildings or its sections located on earth, should be arranged on one level.
10. The foundations of frame buildings in soils of the category III, should be arranged in appearance of crossed continuous footing or unified slab.
11. When the prefabricated continuous footing is supported on soil of the category III, over the foundation the monolithic reinforced concrete belt should be arranged.

12. When the prefabricated continuous foundation is supported on the soil of the category I or II over the foundation there should be arranged the mortar layer of cement grade 100, of thickness no less than 40 mm, with longitudinal reinforcement bars 10 mm over, four, five or six pieces, respectively to seismic intensity 7, 8 and 9. After each 300-400 mm distance, the longitudinal bars should be connected by transversal bars 6 mm over. If basement walls are arranged of prefabricated panels, which are structurally connected to continuous footing, the realization of above mentioned mortar layer is not necessary.
13. The connection of foundations to large bloc masonry of the basement walls should be ensured in each rows, as well as in corners and crossings in depth, as long as 1/3 of the height. The foundation blocks should be arranged as continuous footing. The joint between blocks should be filled by cement mortar of cement grade not less than 50. In case of seismic intensity 9, the basement walls must be monolithic or prefabricated-monolithic.
14. The horizontal hydro-isolation in foundation and the basement structures should be realized of cement mortar of composition 1:2.
15. The basement under the building (or section) should be arranged on one level. The foundation depth must be increased by basement realization (see clause 4 of this item).
16. The rubblework foundations can be used in buildings up to two storey at the design seismic intensity 7. The same time the rubbles must be flat, grade no less than 100, quantity no less than 50 % of masonry total volume and the mortar grade no less than M50. Unbroken rubble stones can be used for foundations one-storeyed buildings in districts of seismic intensity 7, with armored mortar M50 above foundations (see clause 12 of this item). The foundation and basement walls made of rubblework can be used in buildings with number of storeys up to five at the design seismic intensity 7-8, at that the quantity of rubbles grade 100 should not exceed 25 % of total volume of foundations and basement walls. The concrete grade is obtained by the calculation, but no less than B7,5.

Item 8. Buildings with Steel Framework

1. Building steel skeletons for earthquake spread districts should be designed by the following structural schemes:

- a) Frame-like, which longitudinal and transversal beams are connected to the column rigidly in all joints;
- b) braced, with centered and eccentric bonds;
- c) combined, frame-like braced skeleton, braced in one direction of building;
- d) frame-like and frame-like braced in both directions.

2. The options of structural systems of braced skeleton vertical bonds may include:

- a) the skeletons with bonds centered in joints with cross-shaped or single-sided grid;
- b) the skeletons with eccentric bonds, with Z-type, K-type and diamond-shaped grid;

3. In structural scheme selection, the preference is given to closed square or circular schemes, in which the plastic zones (dissipation zones), first of all, arises in skeleton horizontal elements – beams or tensioned and compressed elements of bonds.

4. For frame-like skeleton columns the preference is given to closed square or circular cross-sections. For frame-like braced skeletons, the double tee cross-section columns should be designed. The column joints, brought out to force minimum action zones, are expedient. The beams of frame-like skeletons should be designed with composite double tee beams. In frame-like skeletons, the coupling of beams to box-shaped or double tee cross-sections columns, should be fulfilled using the upper connection detail and supporting platform. In frame-like braced and braced skeletons, the support of beams on columns can be fulfilled by way of free connection, arranging the support platform. In frame-like braced and braced skeletons the girder coupling to the columns should be realized rigidly.

5. The high-rise building with steel skeleton should be designed with the stiffening core, having the skeleton, box-shaped, or space structural scheme.

6. The steel skeleton of one-story industrial building should be designed of overall scheme unified in transversal direction, keeping the even span and height the next way:

- a) industrial buildings, without bridge cranes, the span 18 m and more, divisible by 6,0 m; workshop height – 4,8 m and more, divisible by 0,6 m; the span between the columns in longitudinal direction 6,0 m and more, divisible by 6,0 m;
- b) industrial buildings with bridge cranes - the span 18 m and more, divisible by 6,0 m, workshop height – 8,4 m and more, divisible by 0,6 m; the span between columns in the longitudinal direction 6,0 m and more, divisible by 6,0 m;
- c) the one end of column should be rigidly embedded into foundation, and second end – rigidly or hingedly coupled to covering girders.

7. The vertical joints between the columns should be arranged in each longitudinal row of the building columns, between the same transversal rows, not less than one or two,

respectively to the building short or long section. The number of joints in each row of columns, in the building longitudinal direction, is determined corresponding to their bearing capacity. In buildings without cranes or in building under-crane parts the vertical joints should be located in the midst of building span. In case of arranging two joints in building longitudinal direction, the distance between their axes is accepted no greater than 48 m, when the span between the columns is 6 m, and no greater than 24 m, when the span between the columns is 6 m.

8. To ensure the spatial stiffness of the industrial building steel skeleton, as well as the steadiness of entire covering and its separate elements, there must be considered the brace system between the bearing structures in plane of upper and lower belts, as well as in the vertical plane.

9. In covering of industrial building steel skeleton, the use of the prefabricated reinforced concrete slabs without joints between girders, inadmissible. The coupling between girders can be of three type: with levels, one level, and low. Coupling on one level can be realized with upper and lower connection details, or with upper connection detail and lower platform. The low coupling is realized using the angle bar, upper connection detail and lower platform. In limits of the girder and column coupling the column should be whole.

Item 9. The Design Peculiarities of Reinforced Concrete Structures

1. In strength calculation of bending and eccentrically stressed normal cross-sections, the compressed concrete limit characteristic ξ_r should be accepted with coefficient 0,85 according to the Concrete and Reinforced Concrete Structure Design Building Codes and Rules.
2. In eccentrically compressed elements, as well as in compressed zone of the bending elements, at design seismic intensity 8 and 9, the binders should be arranged by the calculation, on distances : when $R_{ac} \leq 40 \text{ MPa}$ (400 kg/cm^2) – no greater than 400 mm, for wattled grids – no greater than 12d, for welded grids – no greater than 15 d; when $R_{ac} \geq 45 \text{ MPa}$ (450 kg/cm^2) – no greater than 300 mm, for wattled grids – no greater than 10d, for welded grids – no greater than 12 d, where d is the compressed bar minimum diameter. At that, the transversal reinforcement bar should ensure the bending protection in any direction of the compressed bars. The distance between binders of eccentrically compressed elements, in places of overlapping joints between the principal reinforcement bars without welding, should be accepted no greater than 8d. If the total ratio of longitudinal reinforcement of the eccentrically

compressed element exceeds 3%, the binders should be located with distances no greater than $8d$, and no greater than 250 mm.

3. In columns of frame structures of high-rise buildings at intensity 8 and 9 (besides the demands given in clause 2 of this item), the steps between the binders should be no greater than $0,5 h$, and for the skeleton with bearing diaphragm – no greater than h , where h is the minimum size of column rectangular or double tee cross-section. The diameter of the binders, in this case should be accepted no less than 8 mm.
4. In wattled grids the ends of the bindings should be bended around the longitudinal reinforcement bar and pushed into the concrete core in the depth no less than $6d$.
5. For the stocky columns, with ratio of height to maximum size of cross-section $l/h \leq 5$, for increasing the shear bearing capacity, they should be strengthened by diagonal reinforcement, using the welded grids and spirals or binds and studs, with step no greater than 100 mm, so that each longitudinal bar should be fixed - buckling protected in any direction.
6. The elements of high-rise frame building prefabricated columns should be in less detail as much as possible on a few floors. The joints of the prefabricated columns should be located in small moment zones. The junction of the column longitudinal reinforcement bars, without overhead welding is inadmissible.
7. In the prestressed structures, subjected to the load special combination, considering the earthquake effect, the stresses, determined out of the cross-section strength condition, should be 25% greater than stresses, applied to cross-sections at crack formation .
8. In the prestressed structures the use of the reinforcement bars, which specific elongation after rupture – less than 2%, inadmissible.
9. In buildings and structures at design seismic intensity 9 the use of the reinforcement strings and the profiled shape reinforcement bars greater than 28 mm over, without special anchors, inadmissible.
10. In prestressed structures, the reinforcement steel, strained on the concrete, should be placed in closed channels and made monolithic by the concrete or mortar.

Item 10. Framework structures

1. The classification of the framework structure buildings is conducted considering their horizontal seismic load bearing peculiarities.

2. The frame structure is the bar system with rigid joints that bears in full the horizontal loads.

3. Braced-frame structure is the frame-like structure with the additional vertical braces, which bear the horizontal loads together with the frame elements.

4. Braced structure is the structure, in which the elements with rigid braces bear in full the horizontal loads and frame elements bear the vertical loads.

5. In braced-frame and braced structures the bracing elements can be represented as the continuous monolithic walls, frames with infill (stone masonry, prefabricated diaphragms, monolithic diaphragms etc), frames with the diagonal bars, stiffening core etc.

6. Buildings with partial skeleton (buildings, which have stone or brick masonry walls in perimeter, and the skeleton with rigid joints is placed inside the building) inadmissible.

7. In skeleton structures for arranging of bordering walls, the following structures can be used :

a) lightweight suspended panels, which fixing on the skeleton, does not prevent the skeleton deformation under seismic effect;

b) skeleton infill by the stone or brick (natural or manmade, and light concrete among them) masonry that can or cannot bear the seismic effect; if the infill takes part in structure performance then it should be calculated and designed as an united structure; if the infill does not participate in structure performance, it should be calculated according to the clause 14 of item 4.

c) The infill structure steadiness and strength should be ensured by masonry reinforcement (horizontal and vertical), using the framed elements and arranging braces, preventing the infill shear from its plane.

8. In the stone masonry bearing walls the distance between columns (step) should not greater than 6 meter and the wall height – 15m, 12 m and 9 m at seismic intensity 7, 8 and 9, respectively. In mentioned walls, the reinforced concrete belts should be arranged, the way that wall height (distance between belts) is no greater than $12b$, where b is the wall thickness.

9. The bearing walls should have the elastic connection that does not prevent the skeleton horizontal displacement along the walls. Between the wall surface and skeleton columns, the slit no less than 20 mm wide, should be considered. On the wall full length, on the floor level or upper level of window openings, there should be arranged the aseismic belt, connected to the building skeleton by ductile connections. In crossings of end walls and longitudinal walls, the aseismic joint should be arranged along of the building height.

10. In the braced-frame and braced structures the distance between the stiffening elements should be no greater than 18 meter in case of seismic intensity 7 and no greater than 12 meter in cases of intensity 8 and 9.

11. The central zone of the reinforced concrete rigid joints based on calculation, should be strengthened by the diagonal reinforcement (welded grid, spiral or closed binding). If the calculation shows that the diagonal reinforcement is not needed then the mentioned zone should be reinforced by the structural consideration, by the closed transversal reinforcement (binding), of diameter no less than 8 mm and step no greater than 100 mm.

12. On building sites with soils belonging to the category III (Table 1), the construction of high-rise buildings and ones indicated in clause 4 of table 4 is inadmissible.

Item 11. Large-Panel Buildings

1. The large-panel buildings should be designed with longitudinal and transversal through walls united with the floors in a single whole spatial system to bear the seismic load. The projections from outer walls in plane should no greater 3 m. In the design of walls and floor panels, their sizes should be considered for one room. In the buildings with wide pace of transversal walls (greater than 4,2 m), the floor panels composed of two connected elements is admissible.

2. The wall panels should be strengthened by the three-dimensional reinforcement or welded reinforcement grids. The cross-section area of vertical and horizontal reinforced bars in each plane of the panel should consist no less than 0,025 % of corresponding cross-section of the wall. The thickness of the multi-layer panel inner bearing layer should be determined in result of calculation and should be no less than 100 mm.

3. The horizontal and vertical butt-joints of longitudinal and transversal walls and floor panels should be realized by welding of reinforcement bar projections into embedded parts or by some other methods the horizontal and vertical butts should be filled up by fine grain concrete. All end edges of the walls and floor panels to be connected to each other should be fulfilled with indentions or serrated. The depth (height) of indentions or tooth is accepted no less than 4 sm.

4. In wall crossings, the continual vertical reinforcement should be arranged along the building height. The vertical reinforcement should be arranged at the edges of window and door openings as well and in case of the opening regular location, these reinforcement bars should be welded on each floor. The cross-section area of the reinforcement placed in joints and at opening edges should be determined based on calculation but it should be no less than

2 cm². In wall crossings the reinforcement can be placed no greater than 60% of design vertical one.

5. The butt-joints solution should ensure bearing of the design tension and shear forces. The cross-section of steel joints in the panel (horizontal and vertical) butts is determined by the calculation but the minimum cross-section area should be no less than 1 cm² per 1 m of the seam for buildings to be constructed in districts of the design seismic intensity 7-9.

6. The built-in galleries are fulfilled as long as the distance between bearing walls. On building sites of seismic intensity 7, in the plane of the building outer wall where the gallery arranging is considered the reinforced concrete frame should be constructed.

Item 12. Monolithic reinforced concrete frameless buildings

1. The monolithic reinforced concrete buildings should be designed as the structural system of crossing walls with bearing or nonbearing outer walls. In case of the nonbearing outer walls the number of storeys should be no greater than 12, 9 and 5, for seismic intensities 7, 8 and 9 respectively. In these buildings no less than three longitudinal bearing walls must be considered.

2. The use of sliding framework acceptable only at technology, ensuring the continuous concrete casting.

3. The window and door openings should be located in walls the way, that the distance from opening to adjacent wall is no less than 0,6 m.

4. Despite the calculation results there should be arranged the wall reinforcement by the constructional consideration:

a) in wall there should be arranged the vertical and horizontal reinforcement bars, which cross-section area consists no less than 0,05% of the corresponding wall cross-section area;

b) in wall crossings in places of violent change of wall thickness and in opening edges – reinforcement bars with cross-section area no less than 2 cm².

5. The monolithic walls should be strengthened by three-dimensional reinforcement. The flat grid should have the step no greater than 900 mm in case of constructional considerations, and no greater than 400 mm, when there is the calculated wall subjected to the combination of main loads. In this case the vertical reinforcement bar is accepted no less than 10 mm over and the horizontal one – no less than 8 mm over. The horizontal bars connecting the grids should be arranged with step no greater than 600 mm.

6. The three-dimensional reinforcement used in crossings of walls and edges of openings should contain at list two longitudinal reinforcement bars no less than 10 mm over and

closed bindings 3-4 mm over, arranged with step no greater than 300 mm. The change of design reinforcement along the building height should be realized at the expense of the change diameter of the longitudinal reinforcement bars at that their number and distance between the bars should be maintained unchanged. In the reinforcement of narrow up to 1000 mm wide piers there must be used at list four longitudinal reinforcement bars no less than 12 mm over connected to each other by the closed bindings. The bindings should have the step no greater than 400 mm or 20 d. The butt-joint of the three-dimensional reinforcement along the building height should be realized overlapping without welding for the bars up to 20 mm over.

7. To avoid the brittle destruction in vertical butt-joints there should be arranged the horizontal reinforcement bars crossing the vertical butt. The cross-section area of the horizontal bars should be determined proceeding from their bearing capacity.

8. The strengthening of the flat arch should be realized using the three dimensional reinforcement. The outermost longitudinal reinforcement bar should be embedded into the masonry on anchoring length from edge of opening defined by codes but no less than 350 mm. To ensure the steadiness of the longitudinal reinforcement bars located in the compressed zone of the rectangular cross-section flat arch and to exclude their buckling, transversal bars should be embedded. The step of transversal bars should be no greater than 10 d (here d is the minimum diameter of design reinforcement). In construction of the monolithic concrete structures the walls and floors should be verified by the ultrasonic nondestructing method to establish the existence of design reinforcement and concrete range.

Item 13. Buildings of Three-Dimensional Blocks

1. Buildings of three-dimensional blocks should be designed considering entirely moulded or prefabricated three-dimensional blocks. Blocks are integrated into the spatial system bearing the seismic effect.

2. The interconnection between blocks can be realized by the following ways:

- a) welding of embedded parts to the reinforcement bar projections;
- b) concreting the vertical and horizontal seams of butt zones using the fine grain concrete of low shrinkage;
- c) concreting the wells existing between the adjacent in plane blocks;
- d) arranging of the concealed monolithic reinforced concrete skeleton (columns and girders) in indentations between adjacent blocks;
- d) stretching of vertical concrete-enveloped reinforcement bar in conditions of construction.

3. The three-dimensional blocks in bearing walls should be supported along all its length. In the buildings located on sites of seismic intensities 7 and 8 with number of storeys no greater than five and in the buildings located on site of intensity 9, with number of storeys no greater than 2, supporting of the blocks only at their corners, acceptable. At that, the support zone length on each side should be equal to 400 mm.

4. The one-layer walls and bearing layers of the multi-layer three-dimensional block walls should be no less than 100 mm thick. The three-dimensional blocks reinforcement should be realized using the three-dimensional reinforcement or grid of reinforcement bars.

5. The number of inner continuous walls in three-dimensional block buildings, is determined by the calculation and should be at list one.

6. The structural solution of horizontal and vertical seams should ensure the bearing of design stresses. In the three-dimensional block buildings with number of storeys equal to 2, 3 and 5, under construction on building sites of seismic intensities 9, 8 and 7, if in their horizontal joints the tension stresses due to the design loads do not arise - then the consideration of only shear joints between blocks adjacent along the height, acceptable. At that the friction forces which arise in horizontal joints are not considered in calculation. In the rest of the cases necessary cross-section area of the steel connection is determined by the calculation but should not less than:

a) $0,5 \text{ cm}^2$ per one meter of the horizontal joint - in the vertical joints between blocks, adjacent in plane when site seismic intensity is 9 and $0,3 \text{ cm}^2$, at intensities 7 or 8.

b) $1,5 \text{ cm}^2$ per one meter of horizontal joint - in joints between blocks adjacent along the height at that the connections between adjacent blocks can be arranged concentrated at block corners.

7. The integration of the separate three-dimensional blocks along the building height acceptable, if they are stretched in building conditions. The stress value is determined by calculation.

Item 14. Buildings with Large -Block Bearing Walls

1. The design of large-block buildings is realized with two-row or three-row laying in floor limits.

2. The large-block buildings should be constructed of concrete or reinforced pier and reinforced aseismic belt blocks. The lightweight concrete as well as the reinforced concrete hollow blocks should be used. The concrete range for large blocks should be no less than D7,5 and for belt reinforced concrete blocks – no less than B10. The aseismic belt should be

realized using the continuous reinforcement and the connections between the nodes concrete-enveloped.

3. The structural schemes of large-block buildings can be the following:

- a) buildings of blocks in which there are arranged pins to resist to shear forces;
- b) buildings which wall blocks with reinforced vertical connections or the vertical reinforced concrete inclusions resist to the shear and tear forces;
- c) the buildings which vertical reinforced concrete inclusions (or reinforced pier blocks), together with reinforced concrete belts create the skeleton system;
- d) the buildings with the common or prestressed continuous vertical reinforcement of wall blocks, designed as the reinforced concrete structure.

4. The reinforced concrete vertical inclusions should be arranged in wall crossings and breaks. The continuous longitudinal reinforcement (prestressed or common) should pass through the belt block holes. At that the holes and seams should be filled by the cement mortar or fine grain concrete. The mortar and concrete strength can be less than block concrete strength by one step.

Item 15. Buildings with Bearing Walls of Brick, Stone and Concrete Blocks, of Industrial Production

1. For the bearing and self-bearing walls as well as for the skeleton infill that participates in resistance to seismic effect the following wall structures can be used:

- a) the uniform and hollow burnt brick, grade of 75 and greater;
- b) the building tiles grade no less than 100, with the vertical holes no greater than 20 mm over and cavity no greater than 25%.
- c) the uniform and hollow small-size concrete blocks made of lightweight concrete grade of 50 and greater;
- d) small-size blocks of rectangular shape made of natural stones (limestone, tuff etc.) grade no less than 50; on building site of seismic intensity 7 in buildings, with number of storeys no greater than 2 the use of small-size blocks made of natural stones, grade no less than 35, acceptable.
- e) the use of silicate bricks in both bearing and nonbearing elements is inhibited.

2. The strength of mixed cement mortar used in masonry in condition of negative temperature should no less than 50 and in other cases – less than 25. The masonry realization in zones of seismic intensities 7 and 8 in winter conditions acceptable, only using the special

additions in mortar, which ensure the mortar solidification at negative temperature. In the zone of seismic intensity 9 the masonry realization at negative temperature is forbidden.

3. The brick or stone (hereinafter referred to as brick) masonry should be realized by one- row chain-like bond. On building sites of seismic intensity 7 the multi-row masonry use acceptable on condition, that per 3 longitudinal rows are covered by one transversal one.

4. The main characteristic of brick masonry resistance to seismic effect is the force of masonry temporary resistance (normal coherence) to the axial tension R_{nt} , which value should be equal to $R_{nt}=120$ kPa ($1,2$ kg/cm²). To achieve the mentioned value of force of normal coherence ($R_{nt}=120$ kPa), in construction process the rules of brick masonry realization should be kept and the mortar prepared using the special additions, which ensure the increasing of mortar coherence to brick if needed. In construction process in three positions of each floor, the real value of normal coherence should be verified. In case if on object the assurance of mentioned value ($R_{nt}=120$ kPa) of coherence force is not achievable, the brick masonry use is forbidden.

5. The values of masonry design resistance R_t , (axial tension), R_{sq} (shear) and R_{tw} (tension at bending) for coupled seam should be determined based on requirements of stone and reinforced stone structure design and for uncoupled seams – by expressions given below:

$$R_t = 0,45 R_{nt};$$

$$R_{sq} = 0,70 R_{nt};$$

$$R_{tw} = 0,80 R_{nt};$$

where the value of R_t should be accepted according to the data of the tests conducted in district of construction.

The values of R_t , R_{sq} and R_{tw} should be no greater than the corresponding values of brick or stone destruction.

6. Considering the strengthening measures used in masonry with the aim of brick building seismic resistance increasing, 3 types of masonry are distinguished:

- a) I - the brick masonry without strengthening;
- b) II - the brick masonry strengthened by reinforcement;
- c) III - the brick masonry strengthened by complex structures.

7. For all types of brick buildings, the arrangement of aseismic belts on perimeters of longitudinal and transversal walls on the floor level (or under it) represents the necessary aseismic measure. The belt should be of monolithic reinforced concrete with the continuous reinforcement. In the building where floor design is fulfilled using monolithic reinforced concrete slabs and the floor is supported along its contour on the capital walls the belt

arrangement is not necessary. The belt of upper floor and monolithic reinforced concrete slab should be connected to wall masonry by the reinforced concrete anchors. The aseismic belt should be arranged on each floor as wide as the wall. In outer walls, 500 mm wide and more the belt width can be 150 mm less. The belt height should be no less than 150 mm and the concrete range no less than B12,5. The aseismic belts should be arranged with longitudinal reinforcement bars 4d10 at design seismic intensities 7 and 8 and at design seismic intensity 9 – with 4d12.

8. In reinforced conjunctions of the walls (building type II) in masonry, there should be placed the wire, which longitudinal reinforcement cross-section area is no less than 1 cm², and length – no less than 150 cm. For districts of seismic intensities 7 and 8 the distance between the wires in height should be no greater than 70 cm and for intensity 9 – 50 cm.

9. In case of complex structure use (building type III), the brick walls should be strengthened by the reinforced concrete columns working together with the masonry arranged in the wall crossing nodes. The concreting of columns is realized simultaneously with the walls and their tie to the masonry by reinforcement projections is fulfilled the way indicated in clause 8 of this item. The range of concrete used must be no less than B15.

10. In case of brick masonry without strengthening (building type I) the ratio of floor height to wall width should be no more than 10; in buildings strengthened by the reinforcement, the mentioned value should no greater than 12 and in the buildings strengthened by the complex structures – no greater than 15.

11. The height and number of storeys of brick buildings should be no greater than the data given in the table 8.

12. The distance between transversal walls, or substituting reinforced concrete frames, is determined by calculation, and should be no greater than values, given in table 9.

Table 9

N	Type of building walls	Distance, m		
		Design seismic intensity		
		7	8	9
1	Brick masonry types I and II	12	9	6
2	Brick masonry strengthened by complex structures (type III)	15	12	9

13. In the buildings with number of storeys greater than 2 if the distance between longitudinal outer walls exceeds 7m the arrangement of inner longitudinal walls is necessary.

14. The sizes of elements of bearing and self-bearing brick walls are determined by calculation and should meet the values given in the table 10.

Table 10

N	Wall elements	Distance, m		
		Design seismic intensity		
		7	8	9
1	The piers no less wide than	0,77(0,8)	1,16(1,2)	1,55(1,6)
2	The openings no wider than	3,5	3,0	2,5
3	Ratio of pier width to opening width no less than	0,33	0,5	0,75
4	Wall projection out of plan no greater than	2,0	1,0	0

Notes:

1. The width of the corner piers should be increased on 25 cm.
2. The wider openings should be set in reinforced concrete frame.
3. Sizes are given for brick walls (in brackets, for small size blocks).

15. In the buildings with number of storeys greater than 2 in zones of seismic intensity 9, the exits from stairway enclosure should be arranged on building both sides. In the zones of seismic intensities 8 and 9, the window and door openings, existing in stairway enclosure walls should be set in the reinforced concrete frame. The footpaces and their beams should be embedded into wall masonry in depth no less than 250 mm. The bridge boards and prefabricated flights of stairs should be embedded and the footpaces - connected to the floor structure. The arrangement of cantilever stairs embedded into the wall is inadmissible.

16. The straight arches should be arranged wall wide and embedded into the masonry in depth no less than 350 mm. If opening is not wider than 1,5 m, the straight arch embedding into walls in 250 mm depth is acceptable.

Item 16. Buildings Constructed of Local Natural Materials

1. In zones of seismic intensities 7 – 8 there is acceptable construction of buildings using the local materials: regular shape rubble stones, clay – straw blocks, adobe etc. At that on per

60-80 cm height two brick rows should be arranged. The foundation of these buildings should be arranged of concrete or stone materials. The distance between the walls should be no greater than 6 m.

2. In the buildings constructed of local materials on each floor level there should be arranged the aseismic belt made of wood or reinforced concrete. The aseismic belt is arranged using the 10X10 cm cross-section bars, which are placed on the wall outer edge and connected to each other by rectangular 5X10 cm cross-section bars with pace 50 cm.

3. In buildings of mentioned type the wooden beam floors are used, with beams minimum cross-section 10x20 cm and the pace between them no greater than 80 cm; the ends of beams are anchored into the belts.

4. In the prefabricated shield type buildings the walls and bearing partitions should be arranged with bindings, which are connected to foundations by anchors or plaited ropes. Over the walls and partitions the continuous wooden belts should be arranged. The prefabricated shields of the building walls and the partitions should be embedded in the connection joints.

5. The roof bearing structures should be linked to the structures on which they are supported. At that the thrust transmission from rafter to the wall is inadmissible. In sloped roofs the rafters should be anchored into the reinforced concrete or wooden belts. The inferior purlin must be anchored into masonry and embedded into butts in longitudinal direction and in corners. Besides, in the corners there should be placed bracing in appearance of diagonal element.

Item 17. The Structural Demands to Buildings to be Constructed on sites with seismic intensity 6

1. The number of storeys of the building should be no greater than the data of table 8. The building (section) length should be no greater than 100 m.
2. In brick buildings with number of storeys greater than or equal to three at list one inner longitudinal wall should be considered and distance between the transversal walls should be no greater than 16 m. For the brick buildings the arrangement of reinforced concrete belt on the covering level is necessary.
3. In large-panel buildings, the joints between external and internal wall panels should be arranged at list on two levels of each floor.
4. In the reinforced concrete frame and girderless skeleton buildings the central zone of rigid joints should be reinforced by closed bindings with pace no greater than 10 cm, and the zones of columns and girders adjacent to the joints, should be reinforced by

the locked transversal reinforcement bars (bindings), with pace no greater than 15 cm, on distance from the joint equal to 1,5 height of cross-section.

Annex 2.

Production Peculiarities and Construction Work Quality Control

1. In material and ware production and object construction there should be kept the quality level, ensuring the object functioning in standard operation terms.
2. The concrete strength should be determined employing one of the following methods:
 - a) by samples produced in concreting process;
 - b) by samples drilled from structure body;
 - c) by nondestructive method.
3. In concrete strength control by nondestructive method in the structure at list tree control zones must be assigned. The number of controlled structures should consist no less than 15% . In strength control by samples produced simultaneously with the structures, no less than three series of samples should be tested, no later than 5 working days. The sample drilling out of structure body should be conducted, if the results of tests by the first two methods are unsatisfactory.
4. The visual survey and measuring of the reinforced concrete structure reinforcement steel welded joint seam length should be conducted on 15 % of the total quantity. In mechanical testing of welded joints and basic steel no less than six control samples from the test lot should be selected.
5. The strength of mortar coherence to brick or stone in laboratorial conditions, should be determined by the testing results no less than 10 samples from test lots of mortar of given composition and brick or stone. In determination of mortar cohesion to brick or stone in construction conditions there must be conducted no less than five tests on each stage.

6. The mixture shear for masonry of common brick and concrete stones should meet the value of standard cone subsidence – 9– 3 cm, for masonry of hollow brick and building tiles – 7–8 cm. The mortar mixture shear should be selected considering its water holding capacity, water absorption by brick and stone and climatic conditions. The mortar mixture water holding capacity should be no less than 98%.
7. The periodicity and volume of quality control of materials wares and the work execution, should be indicated in the project documentation.
8. The wall masonry should be fulfilled using the one-row tie. The masonry zones in places of coupling with walls should be stowed simultaneously. The stone material stowing should be fulfilled wall wide per row. All seams of masonry to be filled by mortar entirely. The piers, 2,5 brick or less wide, should be stowed by integer bricks, unless for masonry seam tie the unfull-size bricks are needed.
9. The bricks and ceramic tiles with water absorption greater than or equal to 15% m, in dry weather with stable temperature greater than 25⁰C, before stowing should be sunk into the water during no less than 1 minute. Furthermore, the wall masonry should be wet during three days.
10. In the concrete work execution in condition of dry and hot climate, at air temperature greater than 25⁰C, and relative humidity less than 50 % - there should be used the cements, which standard strength exceeds the concrete design grade no less than 20%. The care of new-cast concrete should be continued until it reached 70% of design strength.

Annex 3

Additional Demands to Design of Buildings with Number of Storeys Greater than ones Indicated in Clauses 1, 2 and 3 of Table 8

1. Construction of response spectra for building site, considering the parameters of near and far located seismic sources.

2. Making more precise the response spectra, based on the identification of building site soils, by their seismic properties.
3. Composition of the packet of accelerograms (at list 7), considering the established engineering-geological and seismological parameters.
4. Building calculation by the spatial model employing the multi-modal spectral method and the direct nonlinear dynamical analysis.